

Category 5 Hurricane-RDU Surge Protective Device



Installation and Operation Guide



IMPORTANT: Reading and understanding this installation guide in its entirety is essential prior to installing and commissioning the surge protective device

Safety Precautions

The electrical system on which this surge protection device will be installed must be in proper working condition. Consult with trained personnel before proceeding with the installation, if there are any questions regarding system status. The potential exists for this unit to be damaged if the requirements of this manual are not followed. Failure to comply with the applicable requirements of this manual may result in warranty void. Removal of warranty label will result in warranty void.

Introduction

Proper installation of the Category 5 Hurricane-RDU Surge Protective Device (SPD) is essential to maximize performance and effective protection. Read the entire Installation and Operation Manual prior to beginning installation. This manual does not replace national and local electrical codes. Verify compliance with all electrical codes.

Package Contents & Inspection

Upon receipt of the unit(s), inspect the entire package to ensure there are no signs of damage or mishandling. Remove packing material and inspect device for any obvious shipping damage. Immediately file a claim with the shipping company and inform PSP Products, Inc. if any damage is found that is a result of shipping or handling. Each package contains the following:

- (1) Prewired Surge Enclosure + Remote Display
- (1) Installation and Operation Manual

Product Description

The Category 5 Hurricane-RDU SPD is designed to protect electrical equipment from damaging effects of transient voltages created by direct and indirect lightning strikes, equipment switching or other surge causing disturbances. Metal Oxide Varistor (MOV) technology is utilized to achieve a high level of protection performance. MOVs in the Category 5 Hurricane-RDU units incorporate replaceable modules which allows for efficient maintenance. Each unit comes standard with surge enclosure and remote display; status lights, alarm, and auxiliary contacts, EMI filter and surge counter. The SPD described in this manual are UL Listed, conforming to UL 1283 and latest edition of UL 1449 and CSA 22.2 No.8. The enclosure is rated NEMA 4. All ratings are in accordance with ANSI C62.11, C62.33, C62.41 and NEMA LS1.

The Category 5 Hurricane-RDU is designed so that upon the end of life of a MOV, it will disconnect from the circuit, and signal the need for replacement visually, by auxiliary contacts, and audibly. Consult this manual for instructions on troubleshooting and replacement of MOV modules. The possibility exists of a surge current greater than the rated capacity of an SPD, potentially allowing surge energy through to the protected equipment. Even though the SPD is working properly, additional SPDs may be required. These additional SPDs should be placed closer to the load(s).

Register Online at:
www.pspproducts.com



Important: Risk of electrical shock. This device should only be installed by qualified personnel.

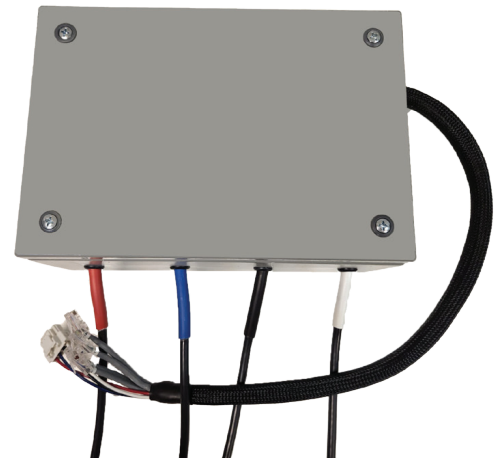

Part Number Breakdown

C5H(#)-(###)-4M-RDU

- **Surge Rating Identifier:** 200=200kA/phase, 400=400kA/phase
- **Voltage Identifier:** 1=120/240 1-phase, 2=120/208 3-phase Wye, 4=277/480 3-phase Wye, 8=220/380 3-phase Wye, 9=240 3-phase delta

Description		C5H1	C5H2	C5H4	C5H8	C5H9
System Voltage	VAC	120/240	120/208	277/480	220/380	240
System Wiring		3W+G (1-Phase Wye)	4W+G (3-Phase Wye)	4W+G (3-Phase Wye)	4W+G (3-Phase Wye)	3W+G (3-Phase Delta)
Maximum Operating Voltage (MCOV)	L-N	150	150	420	300	
	N-G	150	150	275	300	
	L-G	150	150	420	300	300
	L-L	300	300	540	600	300
Voltage Protection Rating (VPR)	L-N	700	700	1,500	900	
	N-G	800	800	1,200	1,200	
	L-G	800	800	1,500	1,200	1,200
	L-L	1,200	1,200	2,500	1,500	1,500
Remote Signal Indicator		250VAC Max 2A				
Follow Current (If)		None				
Maximum Leakage Current (Ipe)		1 mA				
Frequency (f)		50/60/400 Hz				
Nominal Discharge Current Per Mode (In)		20kA				
Maximum Discharge Current (Imax)		200kA–400kA (Depending on Model)				
Short Circuit Current Rating (SCCR)		200kA				
EMI/RFI Filtering		1283 Electromagnetic Interference Filter (-40 dB)				
Thermal Disconnecter		Internal to Each Component				
Overload Disconnecter		Internal to Each Device				
Operating Temperature		-40 to +85°C				
Housing-Enclosure Material		NEMA 4				
Mounting Type		Wall Mount				
Environmental Rating		NEMA 4/12, IP66, Indoor/Outdoor				
Connection Type		Lead Length: 36" / #10 AWG				
Standards Compliance or Recognition		IEC 61643-1- International: Class I & II EN 61643-11- Europe: Class I & II NF EN 61643-11- France: Class I & II CSA C22.2 No. 8-M 1986: Class 9091 32, Class 9091 92 RoHS: Directive 2002 /95/EC UL 1449 5th Edition Type 1 Listed, UL Listed to US and Canadian Safety Standards UL96A Compliant				

Product Pre-Installation

Prior to installing any enclosed SPD, please read and understand the operation manual, ensure that all safety precautions are taken and follow all applicable electrical codes.

1. Power must be disconnected prior to installation. Failure to do so may cause injury, death and/or equipment damage.
2. Ensure that the Category 5 Hurricane-RDU model selected is the proper one for the electrical system and voltage ratings.
3. NEC Article 285 states that Type 2 SPDs may only be placed on the load side of the main breaker or fuse at each utility service entrance.
4. Per National Electric Code (NEC), ensure that a proper neutral-ground bond has been made when power is supplied from an upstream transformer or any other type of separately derived power source. NEC Article 250.30 states this bond must be in place on all 3-phase WYE and 1-phase split systems.

WARNING

Verify that a proper neutral-ground bond has been made when power is supplied from an upstream transformer or any other type of separately derived power source. Power must be disconnected prior to installation, inspection or servicing. Failure to do so may cause injury, death and/or equipment damage.

Failure to provide this bond, as required by NEC 250.30 will void the warranty and can result in elevated phase to ground source voltage potentials. These voltages can cause damage to electrical equipment, pose a fire hazard or a safety hazard such as electrical shock, injury or death.

Installation Instructions

1. Mounting Instructions

Category 5 Hurricane-RDU enclosures are constructed with a NEMA 4 (description below) painted steel enclosure. Refer to dimensions (see dimension drawings). The Category 5 Hurricane-RDU enclosure can be installed in indoor locations as close to the protected circuit as possible. Avoid long wire runs between the SPD and protected circuit, as this will reduce performance. Take care to ensure the surface or structure the unit will be mounted on is stable and capable of bearing the load. Mounting brackets are preassembled on enclosure.

Type 4 enclosures constructed for either indoor or outdoor use to provide a degree of protection to personnel against access to hazardous parts; to provide a degree of protection of the equipment inside the enclosure against ingress of solid foreign objects (falling dirt and windblown dust); to provide a degree of protection with respect to harmful effects on the equipment due to the ingress of water (rain, sleet, snow, splashing water, and hose directed water); and that will be undamaged by the external formation of ice on the enclosure.

2. Wires are color coded to ensure proper connection. L1 is red, L2 is blue, L3 is black, and N (neutral) is white. Connect each wire according to its phase.
3. Power on remote display by connecting 4-pin power connector. Connect RJ45 connectors from surge enclosure to associated RJ45 coupler of remote display. Each connector is labeled 1-4 to match the associated RJ45 coupler labeled 1-4.

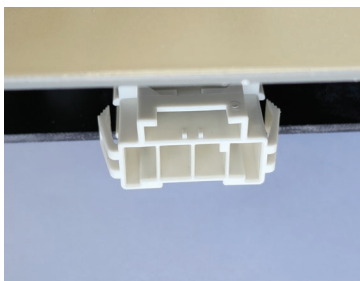

Female 4-pin power connector on remote display

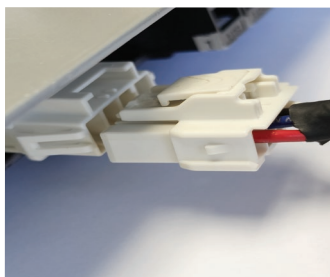

Male 4-pin power connector connecting surge enclosure to remote display



RJ45 coupler on remote display connected to RJ45 from surge enclosure

4. Final Check and Energizing

Ensure that all requirements of this manual have been met and the unit is installed properly. Upon verifying this, power can be re-connected and the unit energized. Once energized check the remote display to observe green LEDs. The unit is now connected and is protecting the circuit.

Maintenance

The design of the Category 5 Hurricane-RDU eliminates the need for preventative maintenance. The remote display will indicate status of SPD and surge capacity remaining. Remote contacts can be wired to allow for notification when a fault is present. Qualified personnel should be used for any inspection or replacement of module within the Category 5 Hurricane-RDU.

Diagnostics

Upon energizing the unit, check to ensure proper operation. The remote display will show green LEDs when no faults are present. Should LEDs appear RED or RED BLINKING check to make sure the electrical network is in good working order and all instructions in this manual have been followed. If the condition persists, remove power to system and consult the troubleshooting section of this manual to determine if any MOV modules are defective. For technical support please contact PSP Products at 703-687-4057.

Remote Display

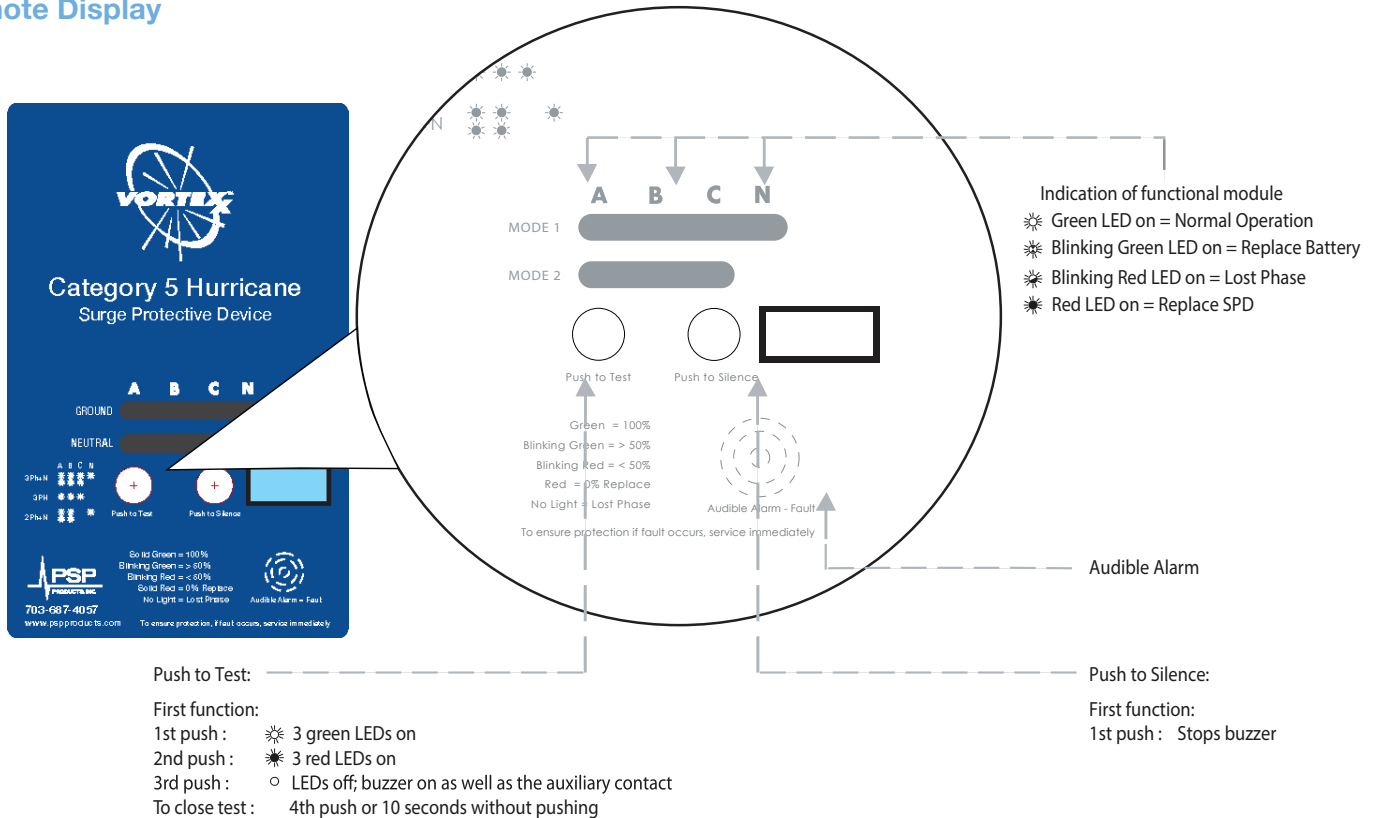

Troubleshooting

First, check the remote display. If all LEDs are green, the unit is working properly. If any LEDs are red or not lit, refer to phase of where red light is indicated or light is not shown. If any module is defective, and needs to be replaced, red flag will appear on the face of the module.

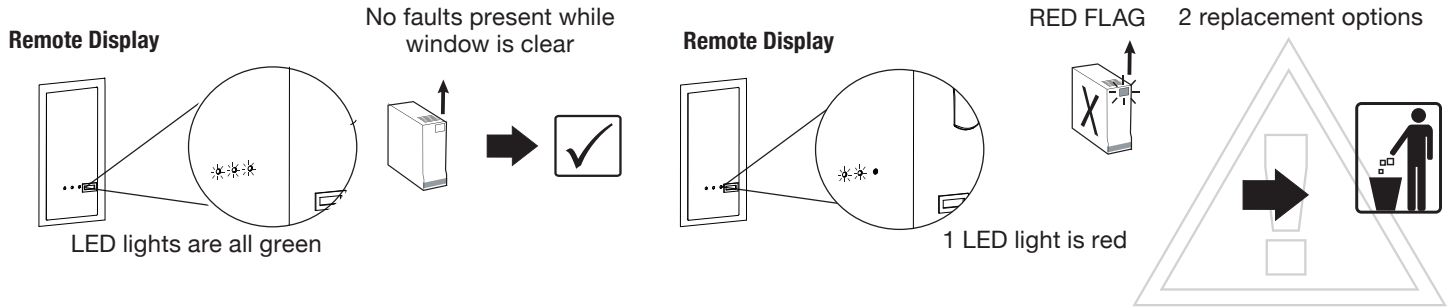

Surge Counter/Diagnostic LCD Display

The counters are small, lithium battery powered, totalizing counters that are panel mounted. The counters are designed as replacements for standard electro mechanical counters. They use the latest custom CMOS technology and incorporate an 8 digit, 0.354" (9mm) high, LCD display. It operates from a long life lithium battery (life 10 years) and can be operated from contact closure or high speed electronic devices. No separate alkaline batteries are required. The front reset button can be enabled by adding a jumper to the lower pins as shown in the illustration below. Jumpers will be included with package contents.

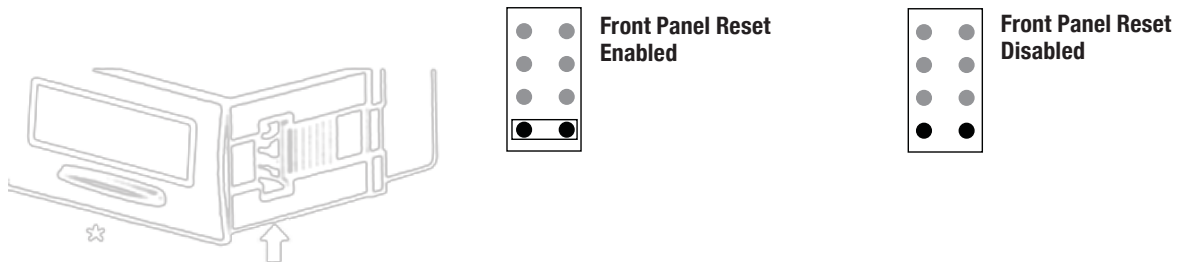

Remote Wiring Dry Contacts

A "form C" contact which is a three wire contact: Normally Open (NO), Normally Closed (NC), and a Common (C). Dry Contacts allows a remote piece of equipment or instrumentation to use its own control loop and loop through the dry contacts. The dry contacts are located on the right side of the remote display and identified by the green terminal connector. The dry contacts are connected to the remote display by red, black, and blue wires. Each wire indicates a position within the contacts.

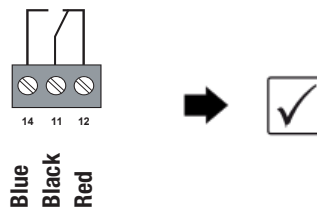
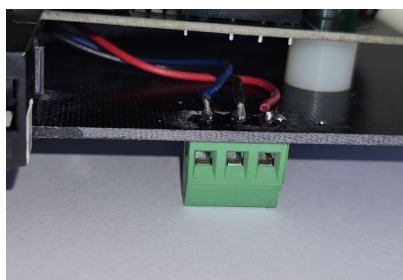

Classification	Standard
Load	Resistive Load
Contact Type	Bifurcated Crossbar
Contact Material	Ag + Au-alloy
Rated Load	0.5A at 125VAC; 2A at 30VDC

Remote Display

Surge Enclosure

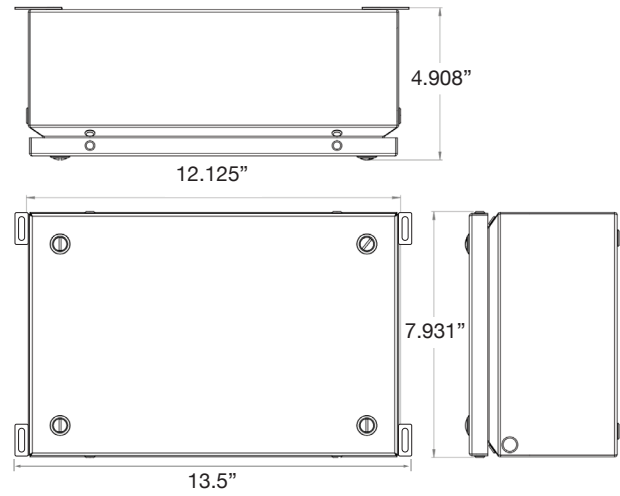
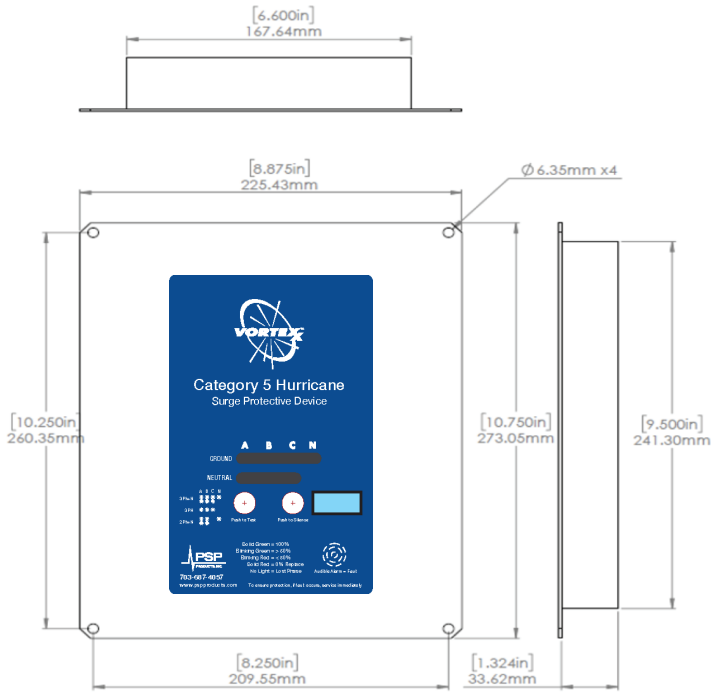

Remote Display

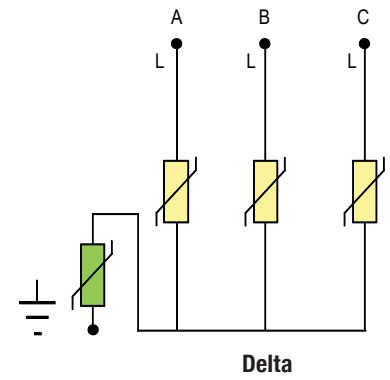
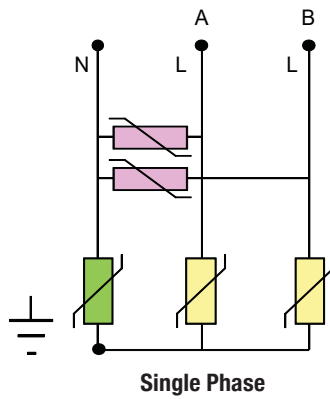
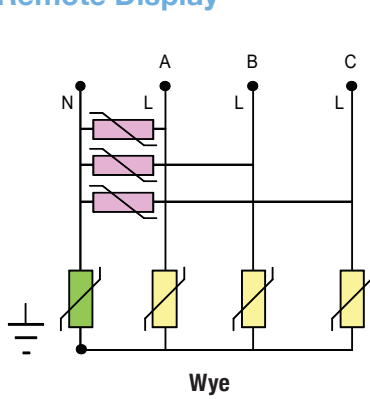

8618 Phoenix Drive
Manassas, VA 20110
703.687.4057
pspproducts.com